

© DEN HARTOG INDUSTRIES, INC.

Copyright. All information furnished within this document, electronic file or design correspondence is the property of Den Hartog Industries, Inc. and shall not be used, disclosed to others or copied without the expressed written consent of Den Hartog Industries, Inc.

4872-36

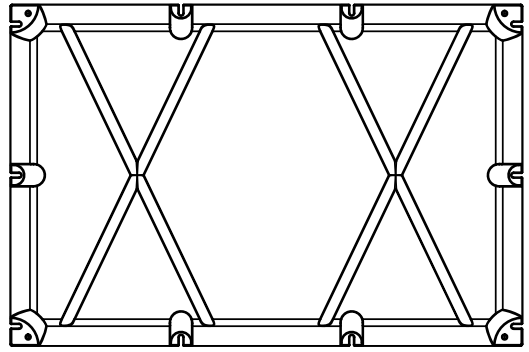
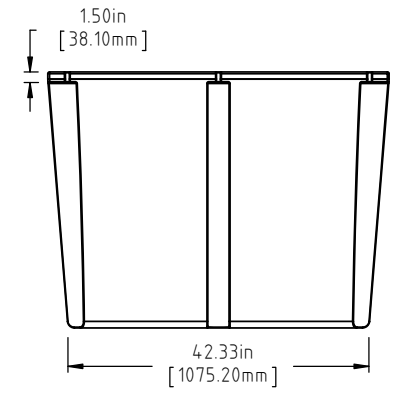
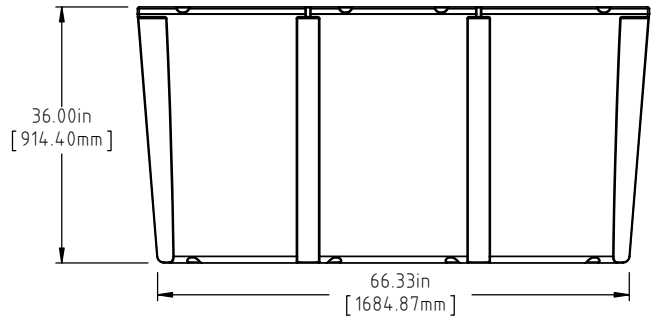
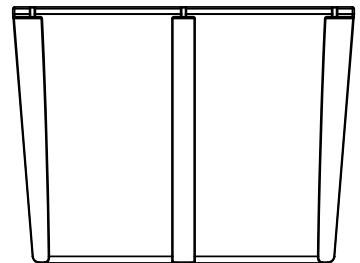
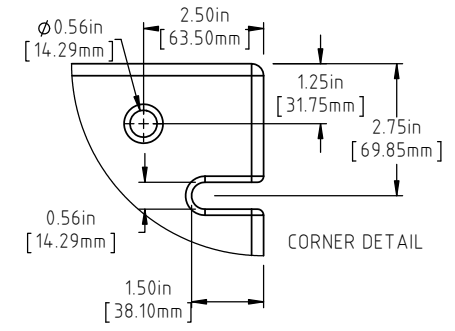
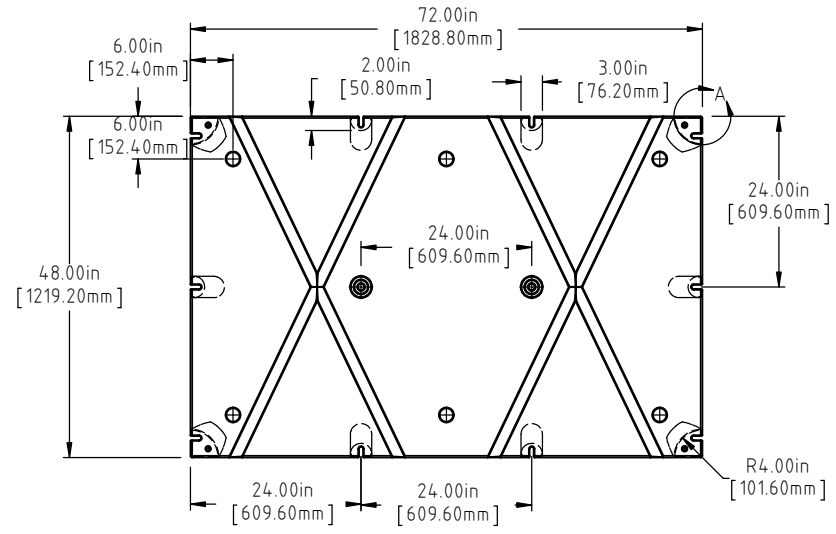

BUOYANCY = 3800 LBS. ( 1724 KG.)

				DRAWN / DATE ADH 7/22/15	MATERIAL POLYETHYLENE
				APPRD. / DATE REH 8/4/15	
REV	DESCRIPTION	BY / DATE	CCN	SHOT WEIGHT: 103 LBS. (47 KG)	NOTES: 1.) AF 103 LBS (47 KG) 2.) FF 166 LBS (75 KG) 3.) .150IN (4.45mm) NOM. WALL
	ALL DIMENSIONS ARE IN DECIMAL INCHES TOLERANCES UNLESS OTHERWISE SPECIFIED			SHIPPING WEIGHT: SEE NOTES	
	POLYETHYLENE			FINISH:	
	±1% @ 68°F				

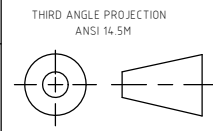

**Den Hartog**  
INDUSTRIES, INC.

Ace Roto-Mold Injection Molding Blow Molding Sowjoy

4010 HOSPERS DRIVE S. BOX 425, HOSPERS, IOWA 51238-0425

DESCRIPTION	48 X 72 X 36 FLOAT	
SCALE	N.S.	PART NO. 4872-36